

Mono 500 Electric Screen Wall Mount - 8430

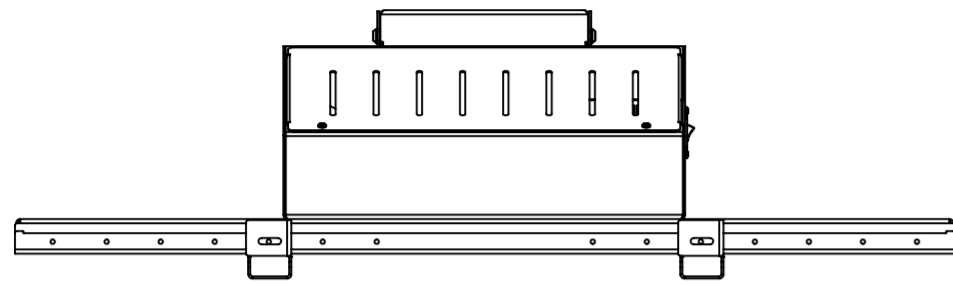

- Max Capacity 130KG, suitable for screens between 42 and 86in
- Suitable for VESA mounts 200, 300, 400, 500, 600, 700 and 800mm in width and between 100 and 600mm in height
- 500mm Electric height adjustment, 840-1340mm Height range to center of mount.
- 4 Gang UK power and 2 x IEC power sockets included inside headbox
- Anti-Collision sensor
- 40mm Standoff Brackets as standard, 100mm standoff brackets available

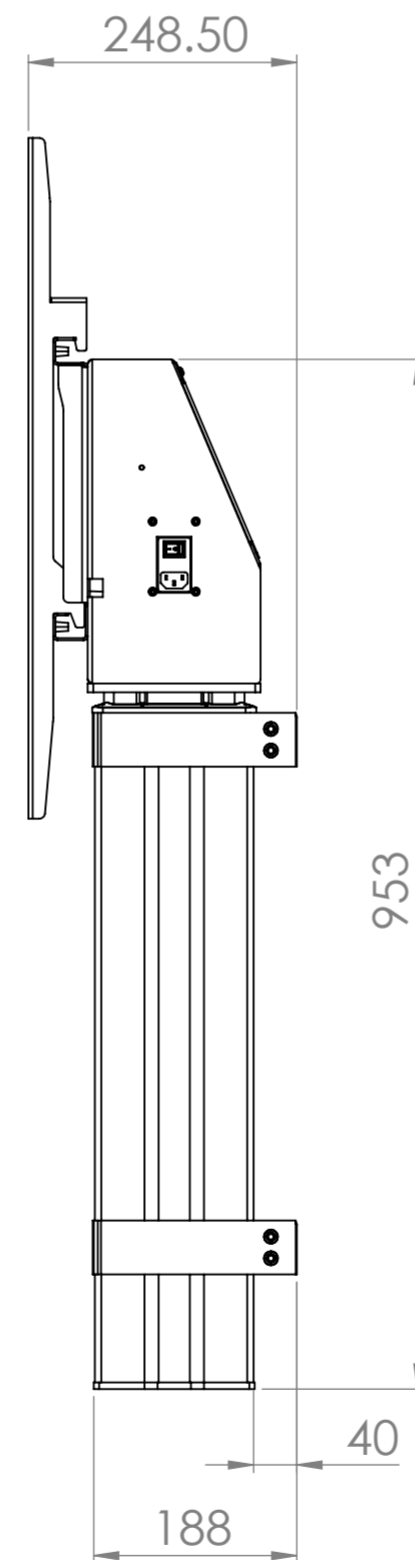
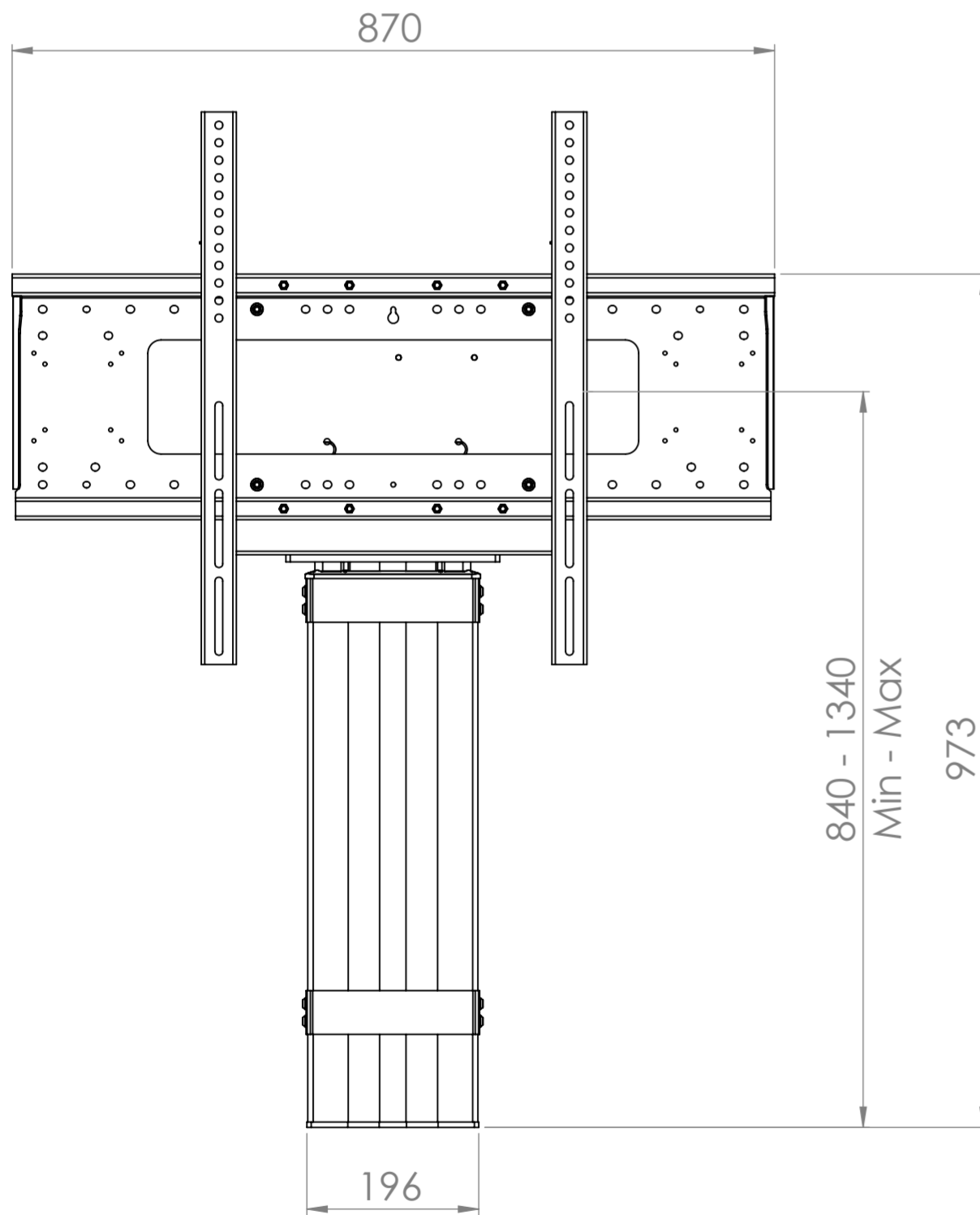
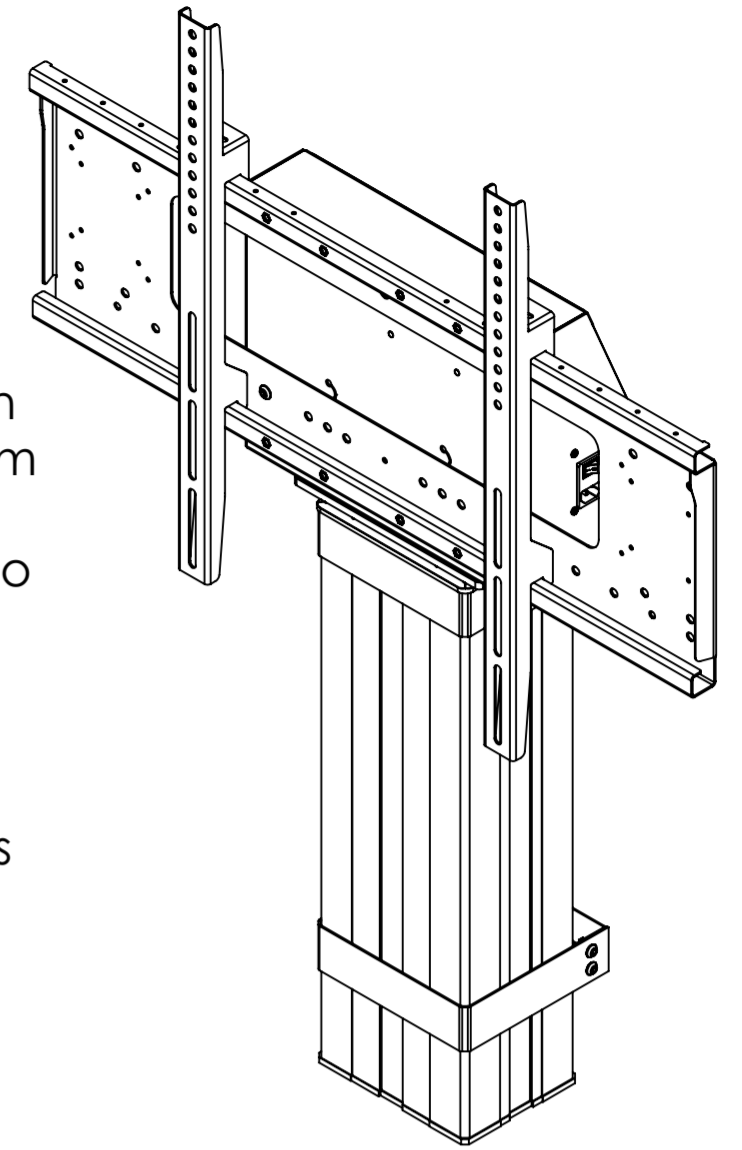

Mount bracket overall dimensions and fixing pattern

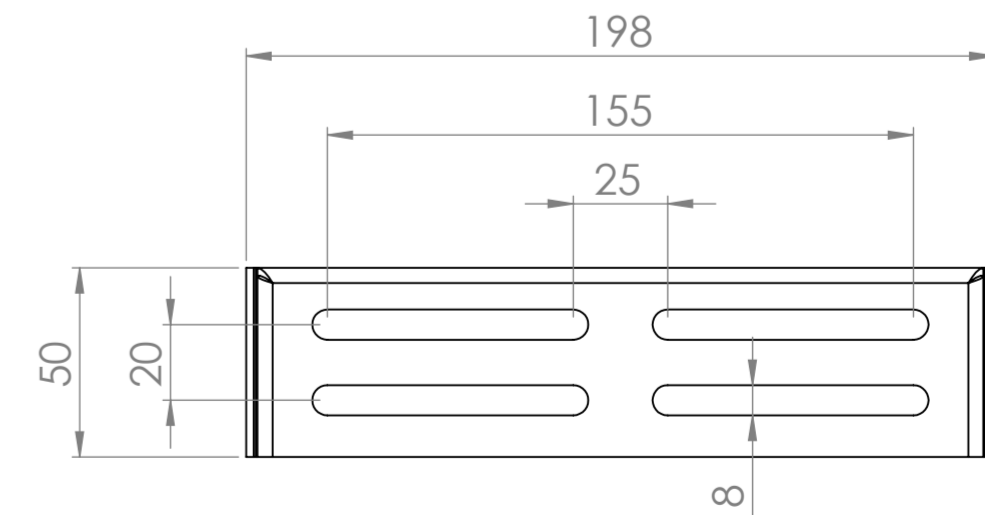

Loxit Limited
 First avenue
 Poynton Industrial Estate
 Poynton
 Cheshire
 England
 SK12 1YJ
t: +44 (0) 845 519 5191
w: www.loxit.com

* Wall Mount shown in lowest position,
 height dimensions do not include adjustable feet

The copyright of this drawing is retained by Loxit limited
 This drawing may not be reproduced without prior written permission of Loxit limited

*Dimensions given to a tolerance of +-3mm